

NOVA 4-30-B8 P20 LW

Inrunner BLDC motor with closed housing

Overview

The NOVA 4 Light-Weight ("LW") is from our family of super rugged inrunner BLDC motors and has been designed for a wide range of mission critical applications.

Features

- Super robust housing for applications in the harshest environments
- Best power-to-weight-to-robustness ratio in its class
- Wear-free position and temperature sensors included in standard
- Optimized shaft for Plettenberg propeller coupling

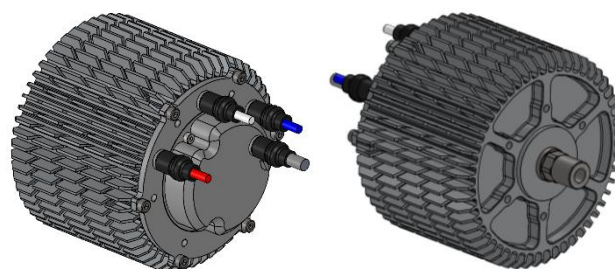

Specifications

Part number	02-029.030.12-000-047	
Peak output power	2.4	kW
Peak torque (max. 5s) ⁽¹⁾	4	Nm
Max. speed	11,000	rpm
Voltage range	15-36	V
Speed constant (kV)	279	rpm/V
Diameter	79	mm
Length	61	mm
Weight	700	g
Phase cable length	100	mm
Sensor cable length	400	mm
Recommended phase cable extension	4	mm ²
	12	AWG
Protection class	IP54	
Mounting	Front & back	
Direction of rotation	Both	
Cooling	Air cooled	
Ambient temperature range	-20 to +60	°C
Max. temperature of stator (as measured by sensor)	+100	°C
Position sensor types	Hall effect sensor with UVW-commutation signals	
Temperature sensor	NTC 47 kΩ	
Number of poles	20	
Number of windings	8	
Phase resistance ⁽²⁾	27	mΩ
Phase inductance ⁽²⁾	30	μH
Peak thrust	12.5 kg with 22x7.4" prop	

Notes:

- (1) Peak torque with sensor-guided ESC. If using sensorless ESC, peak torque may be 10-20% lower.
 (2) Phase-to-phase value

Complementary Products

- Plettenberg propeller coupling: PC LW 6K 10mm
- Plettenberg gold connectors: GC6-00 / GC6-90

Heatmap

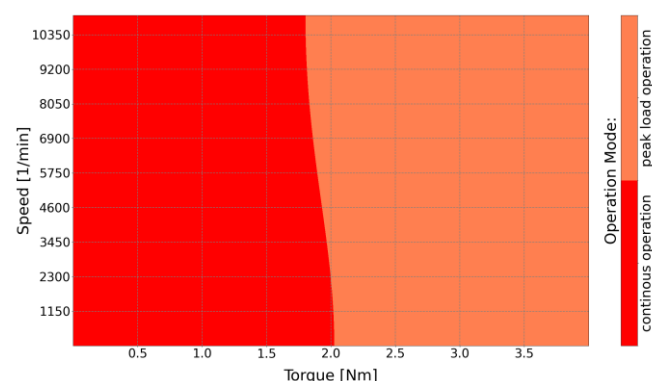

Note: Assuming 25°C ambient temperature and 10 m/s airflow at MSL.

Options & Customization

- Custom winding/kV versions
- MIL-STD 810H test reports
- MTBF/S report
- IP67 protection class
- Aerospace or MIL-DTL-38999 connectors
- Mechanical customization or frameless kits
- High/low temperature versions
- High RPM versions
- Propeller study
- RTCA DO160 qualification



NOVA 4-30-B8 P20 LW

Inrunner BLDC motor with closed housing

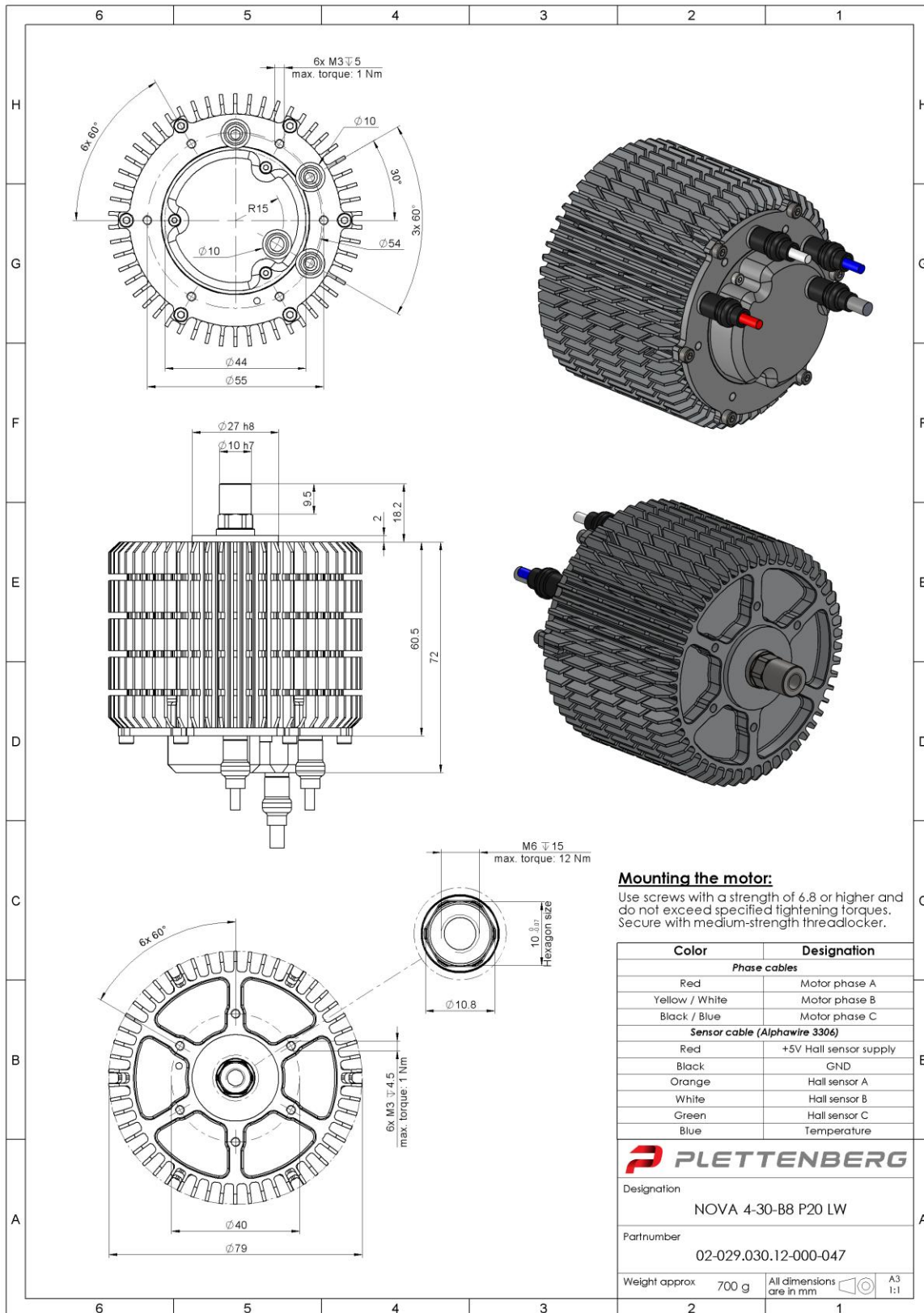

Plettenberg Elektromotoren GmbH & Co. KG
 Rostocker Straße 30
 34225 Baunatal, Germany
 T: +49 (0) 56 01 97 96-0
 www.plettenbergmotors.com / sales@plettenbergmotors.com
 © 2026 Plettenberg Elektromotoren GmbH & Co. KG. All rights reserved.

