

NOVA Series

NOVA 15-20-B6 P30 LW

Inrunner BLDC motor with closed housing

Overview

The NOVA 15 Light-Weight ("LW") is from our family of super rugged inrunner BLDC motors and has been designed for a wide range of mission critical applications.

Features

- Super robust housing for applications in the harshest environments
- Best power-to-weight-to-robustness ratio in its class
- Wear-free position and temperature sensors included in standard
- Optimized shaft for Plettenberg propeller coupling

Specifications

Part number	02-044.020.12-000-340	
Peak output power	6	kW
Peak torque (max. 5s) ⁽¹⁾	16	Nm
Max. speed	8,000	rpm
Voltage range recommended	15-50	V
Speed constant (kV)	170	rpm/V
Diameter	138	mm
Length	53	mm
Weight	1,500	g
Phase cable length	100	mm
Sensor cable length	400	mm
Recommended phase cable extension	8	mm ²
	8	AWG
Protection class	IP54	
Mounting	Front & back	
Direction of rotation	Both	
Cooling	Air cooled	
Ambient temperature range	-20 to +60	°C
Max. temperature of stator (as measured by sensor)	+100	°C
Position sensor types	Hall effect sensor with UVW-commutation signals	
Temperature sensor	NTC 47 kΩ	
Number of poles	30	
Number of windings	6	
Phase resistance ⁽²⁾	14	mΩ
Phase inductance ⁽²⁾	19	μH
Peak thrust	31 kg with 32x10.6" prop	

Notes:

⁽¹⁾ Peak torque with sensor-guided ESC. If using sensorless ESC, peak torque may be 10-20% lower.

⁽²⁾ Phase-to-phase value

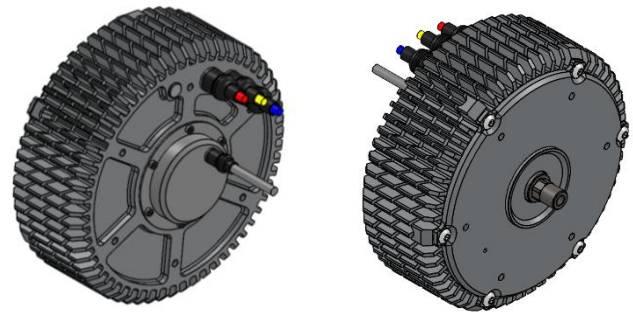

Complementary Products

- Plettenberg propeller coupling: PC LW 6K 10
- Plettenberg gold connectors: GC6-00 / GC6-90

Heatmap

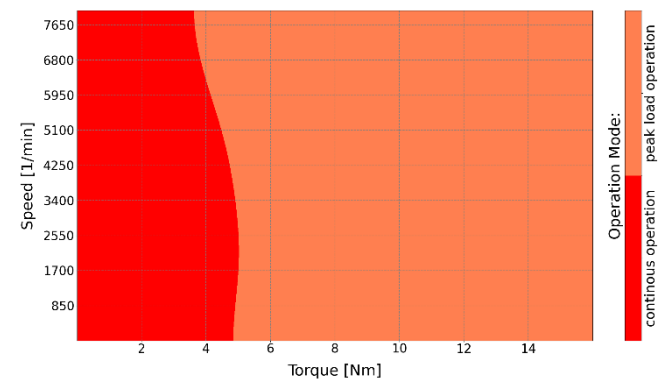

Note: Assuming 25°C ambient temperature and 10 m/s airflow at MSL.

Options & Customization

- Custom winding/kV versions
- MIL-STD 810H test reports
- MTBF/S report
- IP67 protection class
- Aerospace or MIL-DTL-38999 connectors
- Mechanical customization or frameless kits
- High/low temperature versions
- High RPM versions
- Propeller study
- RTCA DO160 qualification



NOVA 15-20-B6 P30 LW

Inrunner BLDC motor with closed housing

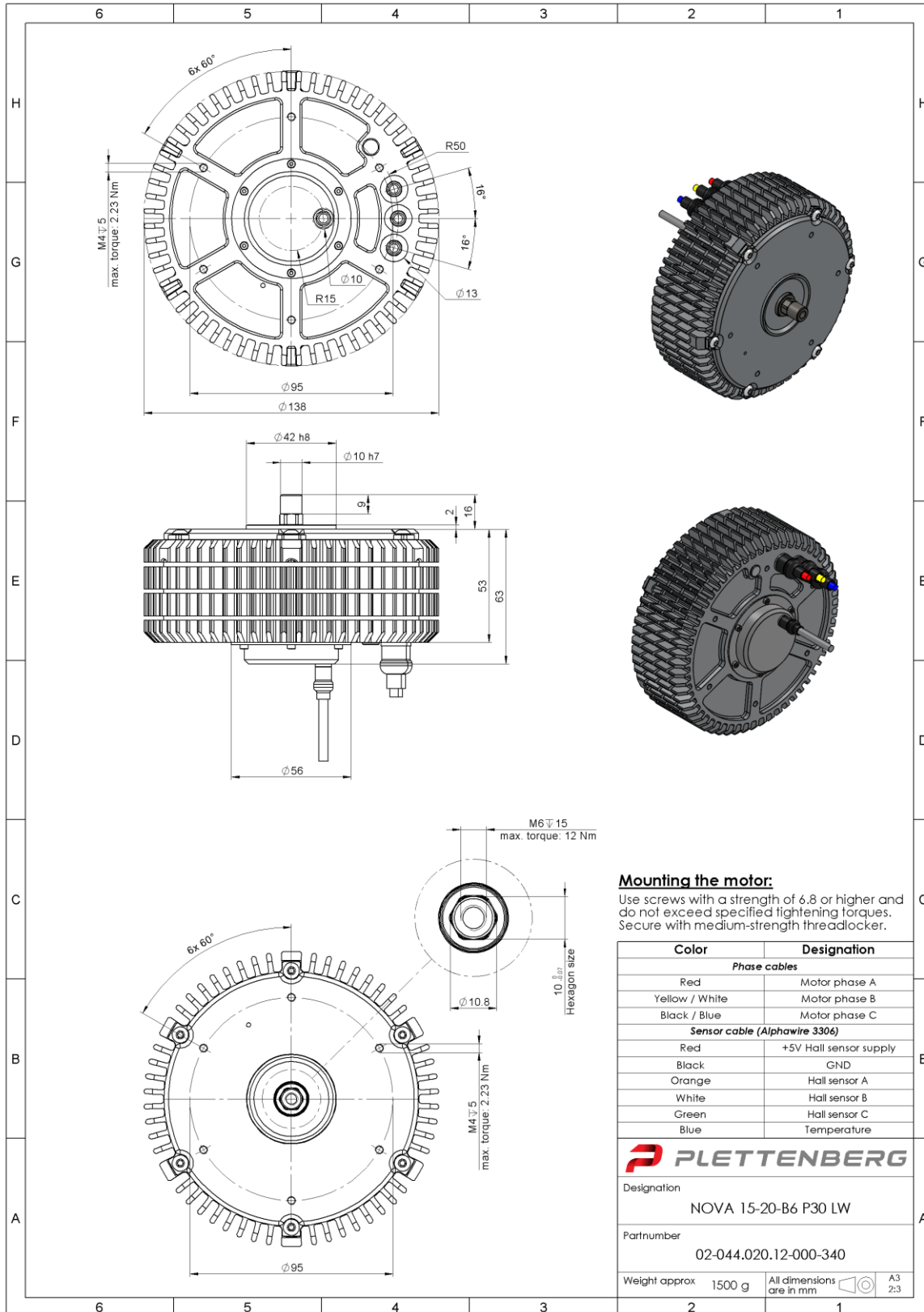

We reserve all rights for this drawing, also in case of patent grant or utility model registration. Without our prior consent, this drawing may neither be reproduced nor made available to third parties, and it may not be issued by the recipient or third parties in any other way. Infringements will be liable to damages and may result in criminal prosecution. Plettenberg Elektromotoren GmbH & Co. KG

Plettenberg Elektromotoren GmbH & Co. KG
 Rostocker Straße 30
 34225 Baunatal, Germany
 T: +49 (0) 56 01 97 96-0
 www.plettenbergmotors.com / sales@plettenbergmotors.com
 © 2026 Plettenberg Elektromotoren GmbH & Co. KG. All rights reserved.

