

NOVA Series

NOVA 15-50-B8 P30 WK

Inrunner BLDC motor with closed housing



Overview

The NOVA 15 Water-Cooled ("WK") is from our family of super rugged inrunner BLDC motors and has been specifically designed for mission critical applications.

Features

- Super robust housing for applications in the harshest environments
- Designed for high shock and vibration loads
- Qualified to MIL-STD 810H
- Wear-free position and temperature sensors included in standard

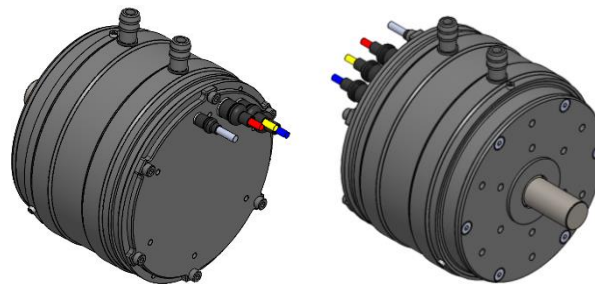

Specifications

Part number	02-044.050.01-000-352
Peak output power	15 kW
Peak torque (max. 5s) ⁽¹⁾	40 Nm
Max. speed	8,000 rpm
Voltage range	30-160 V
Speed constant (kV)	48 rpm/V
Diameter (ex. water inlet)	131 mm
Length	97 mm
Weight	3,200 g
Phase cable length	100 mm
Sensor cable length	400 mm
Recommended phase cable extension	6 mm ² AWG
Protection class	IP54
Mounting	Front & back
Direction of rotation	Both
Cooling	Water cooled
Ambient temperature range	-20 to +60 °C
Max. temperature of stator (as measured by sensor)	+100 °C
Position sensor types	Hall effect sensor with UVW-commutation signals
Temperature sensor	NTC 47 kΩ
Number of poles	30
Number of windings	8
Recommendations for water cooling	Flow of 7 liters-per-minute at max. 40°C inlet temp.; coolant pressure shall not exceed 2 bar/ 29 PSI.

Complementary Products

- Plettenberg ESCs: MST 60-260, MST 60-290, MST 60-130, MST 80-240, MST 80-350, MST 140-200
- Third party ESC from Allocortech
- Plettenberg gold connectors: GC6-00 / GC6-90

Heatmap

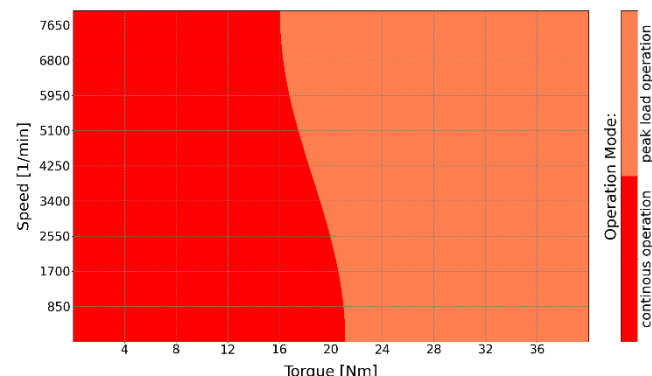

Note: Assuming water temperature of 40°C and 7 l/min flow.

Options & Customization

- Custom winding/kV versions
- MIL-STD 810H test reports
- MTBF/S report
- IP67 protection class
- Aerospace or MIL-DTL-38999 connectors
- Mechanical customization
- High RPM versions
- RTCA DO160 qualification

Notes:

⁽¹⁾ Peak torque with sensor-guided ESC. If using sensorless ESC, peak torque may be 10-20% lower.

Plettenberg Elektromotoren GmbH & Co. KG
Rostocker Straße 30
34225 Baunatal, Germany
T: +49 (0) 56 01 97 96-0
www.plettenbergmotors.com / sales@plettenbergmotors.com
© 2025 Plettenberg Elektromotoren GmbH & Co. KG. All rights reserved.



NOVA 15-50-B8 P30 WK

Inrunner BLDC motor with closed housing

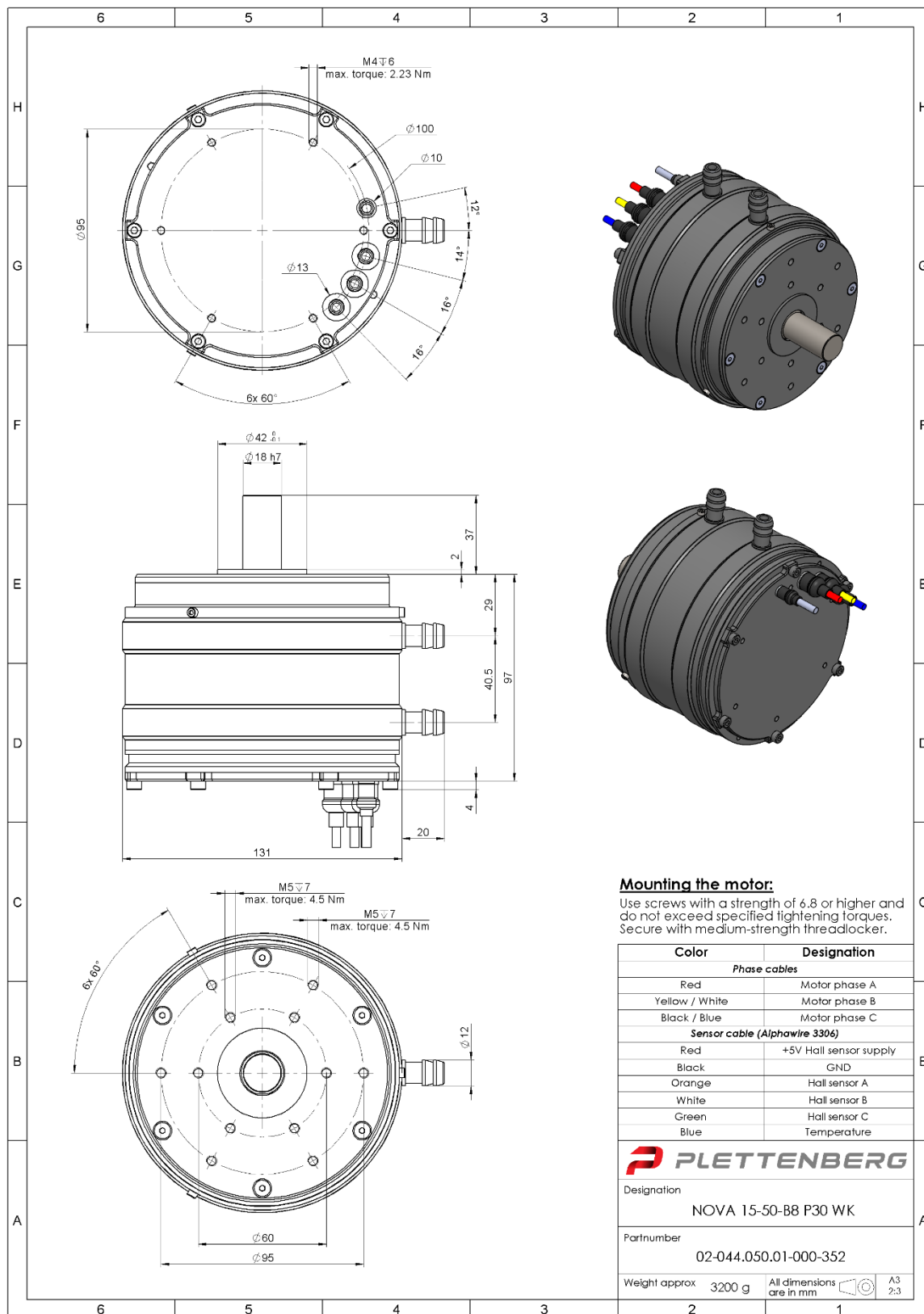

Plettenberg Elektromotoren GmbH & Co. KG
 Rostocker Straße 30
 34225 Baunatal, Germany
 T: +49 (0) 56 01 97 96-0
 www.plettenbergmotors.com / sales@plettenbergmotors.com
 © 2025 Plettenberg Elektromotoren GmbH & Co. KG. All rights reserved.

