

NOVA Series

NOVA 30-50-B4 P50 WK

Inrunner BLDC motor with closed housing



Overview

The NOVA 30 Water-Cooled ("WK") is from our family of super rugged inrunner BLDC motors and has been specifically designed for the most demanding applications.

Features

- Super robust housing for mission critical applications
- Best power-to-weight-to-robustness ratio in its class
- Position and temperature sensors included in standard



Specifications

Peak output power	30	kW
Peak torque ¹	80	Nm
Max. speed	5,000	rpm
Voltage range	30-120	V
Speed constant (kV)	37	rpm/V
Diameter (ex. water inlet)	197	mm
Length	93	mm
Weight	6,300	g
Phase cable length	100	mm
Sensor cable length	400	mm
Protection class	IP53	
Cooling	Water cooled	
Ambient Temperature range	-20 to +60	°C
Max. temperature of stator (as measured by sensor)	+100	°C
Position sensor types	Hall effect sensor with UVW-commutation signals	
Temperature sensor	NTC 47 kΩ	
Number of poles	50	
Number of windings	4	
Recommendations for water cooling	Flow of 7 liters-per-minute at max. 40°C inlet temp.; coolant pressure shall not exceed 2 bar/ 29 PSI.	

Complementary Products

- Plettenberg ESCs: MST 140-200, MST 140-250 WK
- Plettenberg gold connectors: GC6-00 / GC6-90

Notes:

¹ With sensor-guided ESC

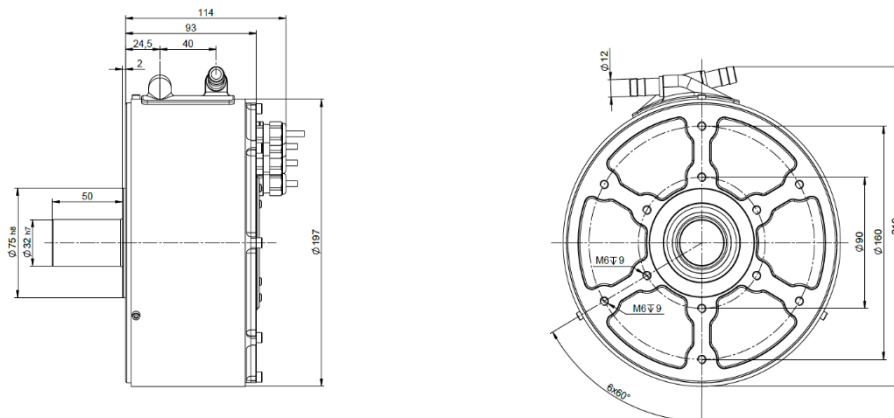

Plettenberg Elektromotoren GmbH & Co. KG

Rostocker Straße 30

34225 Baunatal, Germany

T: +49 (0) 56 01 97 96-0

www.plettenbergmotors.com / sales@plettenbergmotors.com

© 2024 Plettenberg Elektromotoren GmbH & Co. KG. All rights reserved.

