

Mounting the motor

Use the bollow prescribed torque when bolting the motor
The bolts must be of quality 8.8 or higher

- The motor is fixed with 6x M6 bolts
- Maximum screw-in depth: 9 mm
- Maximum tightening torque: 10,2 Nm

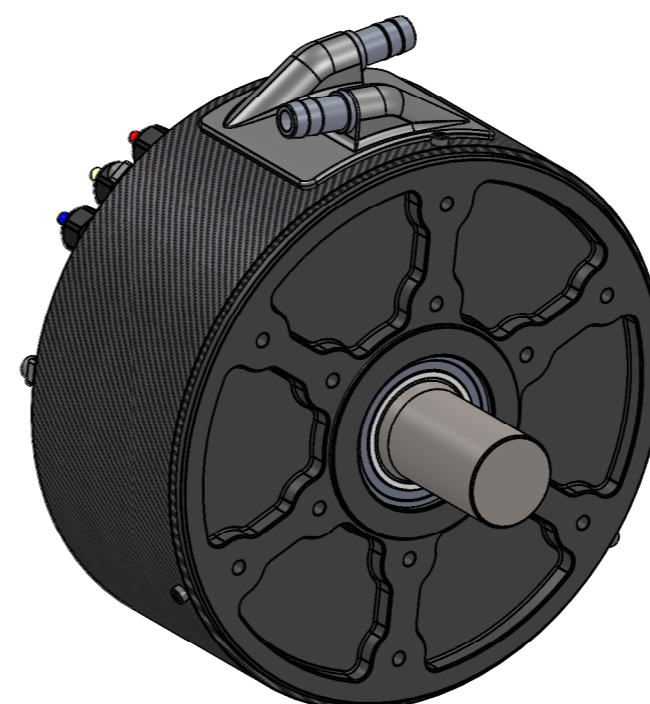

all dimensions are in mm

Weight approx: 6300 g



NOVA 30-50 WK

sample dimension sheet

A3

We reserve all rights for this drawing, also in case of patent grant or utility model registration.
Without our prior consent, this drawing may neither be reproduced nor made available to third parties, and it may not be misused by the recipient or third parties in any other way. Infringements will be liable to damages and may result in criminal prosecution.
Plettenberg Elektromotoren GmbH & Co. KG