

M8x1.25 HELICOIL
 Free running thread insert
 Thread depth: 8 mm
 Max. screw depth: 10 mm
 Max. fastening torque: 9.3 Nm

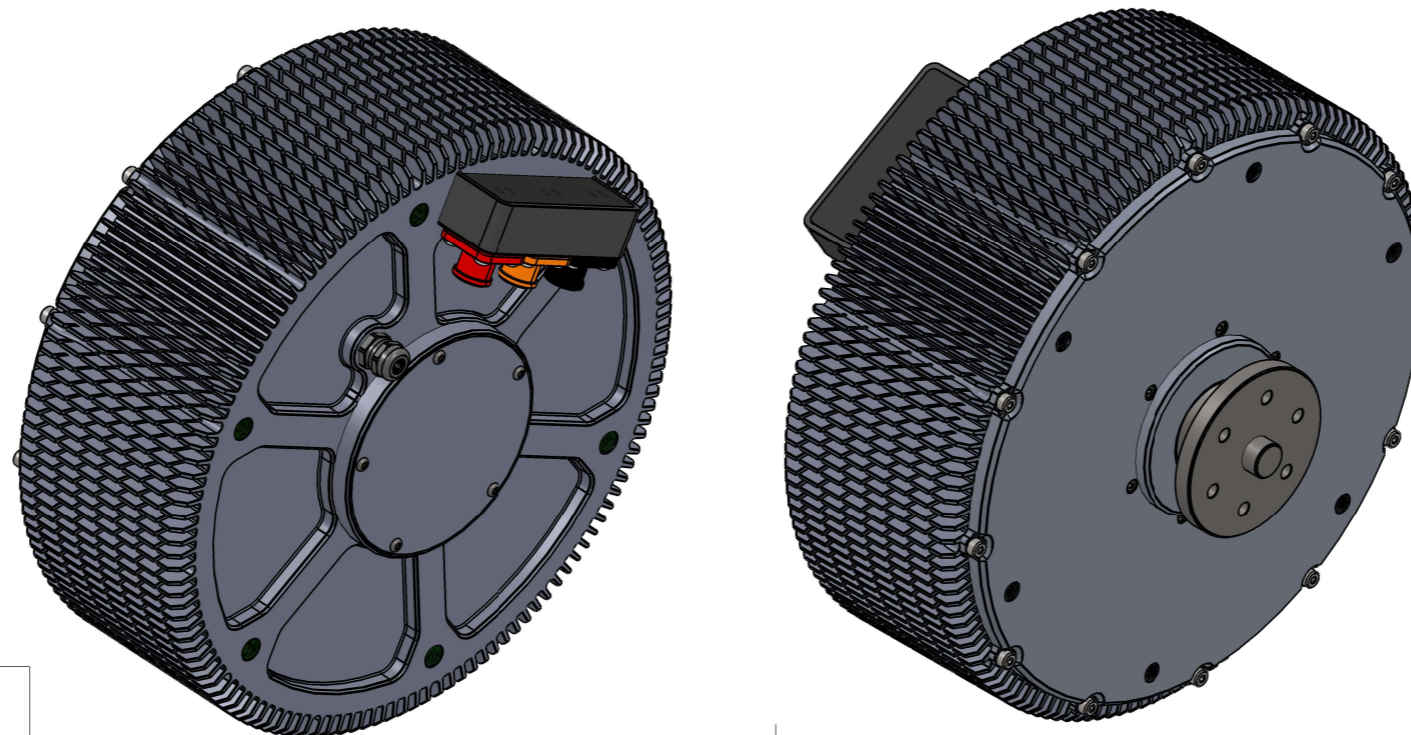

all dimensions are in mm Weight approx: 11500 g

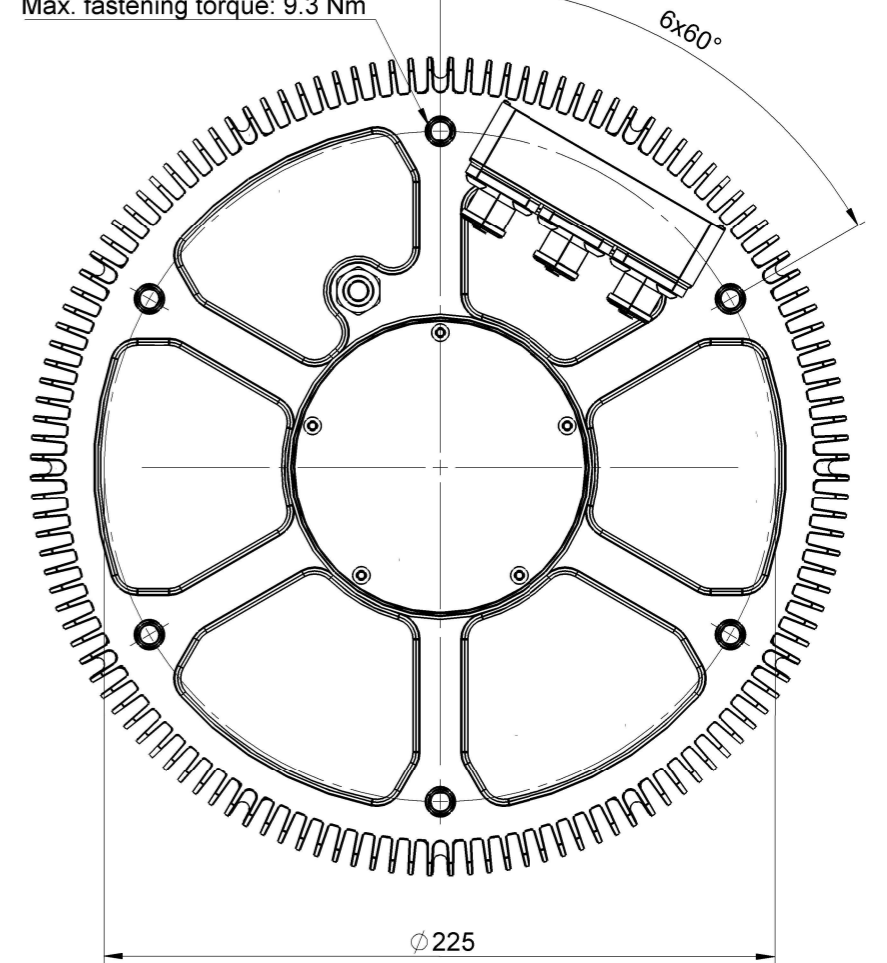

NOVA 50-50

sample dimension sheet

A3

We reserve all rights for this drawing, also in case of patent grant or utility model registration.
 Without our prior consent, this drawing may neither be reproduced nor made available to third parties, and
 it may not be misused by the recipient or third parties in any other way. Infringements will be liable to damages
 and may result in criminal prosecution. Plettenberg Elektromotoren GmbH & Co. KG